

TDS-IGL21L



ELEVATOR TRACTION MACHINE

Suspension	2 : 1
Voltage	380V
Pole	32
Rating	S5 (40%)
INS. Class	F
IP Code	IP41
FZD12C Brake	DC110V 2x1.5A
Max. Static Load	3500 kg
Weight	350 kg

DIMENSIONS

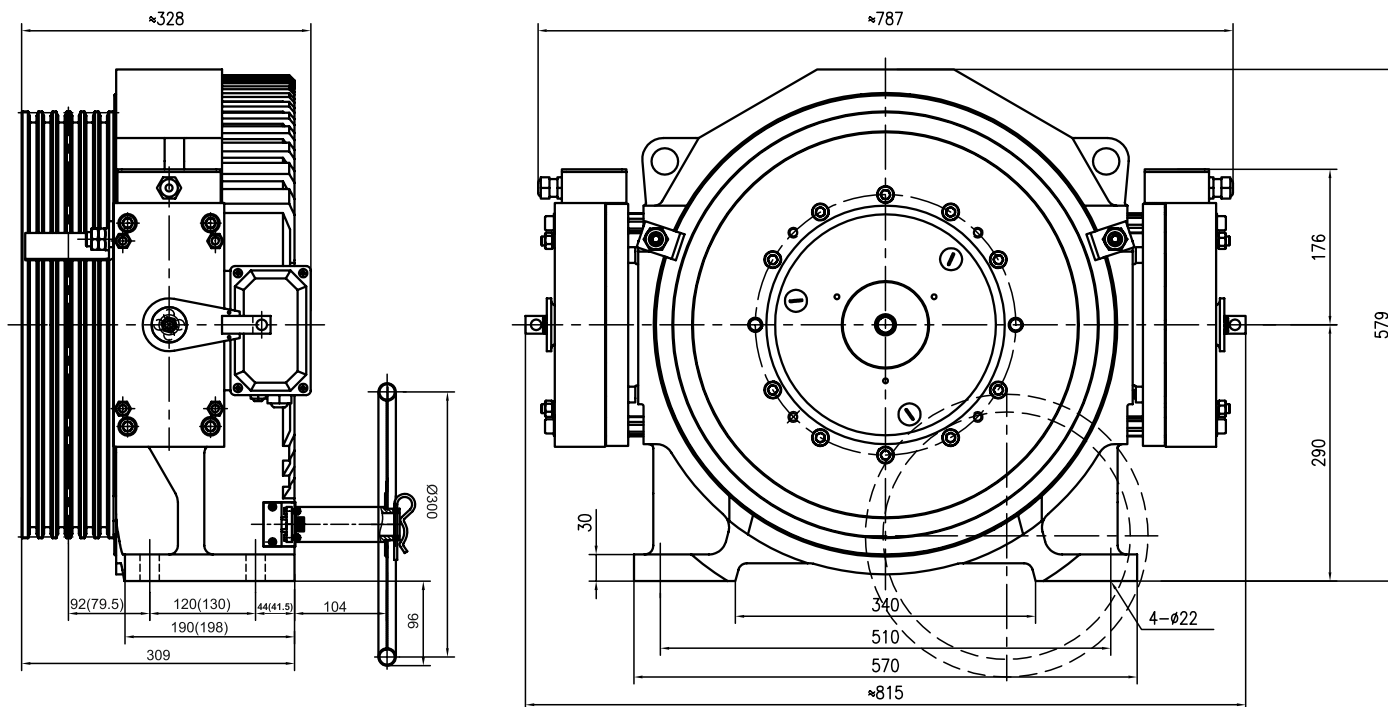

TECHNICAL DATA

Spec	Load (kg)	Lift Speed (m/s)	Sheave Dia.(mm)	Rope Groove (mm)	Current (A)	Torque (Nm)	Rated Speed (rpm)	Frequency (Hz)	Power (kW)
TDS-IGL21L-82P0-10MM	884	2.0	ø480	5xø10x16	22.3	592	159	42.4	9.9
TDS-IGL21L-82P5-10MM		2.5			28.4	592	200	53.3	12.4
TDS-IGL21L-102P0-10MM	1088	2.0	ø480	6xø10x16	30	780	159	42.4	13
TDS-IGL21L-102P5-10MM		2.5			35.6	780	200	53.3	16.3
TDS-IGL21L-111P0-10MM		1.0			17	750	96	25.6	7.5
TDS-IGL21L-111P5-10MM	1156	1.5	ø400	6xø10x16	26	750	144	38.4	11.3
TDS-IGL21L-111P7-10MM		1.7			28	750	167	44.5	13.1
TDS-IGL21L-112P0-10MM		2.0			33	750	192	51.2	15.1
TDS-IGL21L-121P0-10MM		1.0			18.5	810	96	25.6	8.1
TDS-IGL21L-121P5-10MM	1292	1.5	ø400	6xø10x16	28.3	810	144	38.4	12.2
TDS-IGL21L-121P7-10MM		1.7			30.3	810	167	44.5	14.2
TDS-IGL21L-122P0-10MM		2.0			35.6	810	192	51.2	16.3
TDS-IGL21L-131P0-A-10MM		1.0			20.0	856	96	25.6	8.6
TDS-IGL21L-131P5-A-10MM	1360	1.5	ø400	6xø10x14	30.5	856	144	38.4	12.9
TDS-IGL21L-131P7-A-10MM		1.7			33.0	856	167	44.5	15.0

REMARK

1. For machine room less, the standard configuration of this machine does not include manual brake release. Customers are required to provide their own electric brake release device.
2. The manual brake release is optional to provide if the customer need it.
3. The dimension in bracket are for 1360Kg Machine.